

ASSAM POWER GENERATION CORPORATION LIMITED

OFFICE OF THE CHIEF GENERAL MANAGER (HYDRO & CIVIL),

BIJULEE BHAWAN, GUWAHATI-781001



NIT NO: - Tender Notice No. 21 of 2019-20 of CGM (H&C) dtd: 06.02.2020

NAME OF THE WORK: Construction of Steel Bracing Saddle Blocks at Myntriang
Small Hydro Electric Project, Stage-I, APGCL, Karbi Anglong
(Group-B)

February-2020

Issued to:

Name:-

Address: -

Issued by:

Price: - ₹1000/-
(Non-Refundable)

INDEX

<u>Chapter</u>		<u>Page No</u>
Chapter-I	Tender Notice 2
Chapter-II	Terminology 4
Chapter-III	Instruction for bidders and special Conditions 5
Chapter-IV	Safety Engineering and Safety Code 11
Chapter-V	Contractor's Camp 12
Chapter-VI	Declaration 13
Chapter-VII	Declaration of litigation 14
Chapter-VIII	Schedule of works 15
Chapter-IX	Drawings 18

CHAPTER-I

TENDER NOTICE



ASSAM POWER GENERATION CORPORATION LIMITED

Registered Office: Bijulee Bhawan, 2nd floor, Paltanbazar, Guwahati-781 001, Assam.

Email: cgmh2010@yahoo.in, Tele-Fax: 0361-2739522.

Ratnajit Biswanath

Chief General Manager (Hydro & Civil)

(4)

Notice No. APGCL/CGM (H&C)/21 of 2019-20

Date: 06/02/2020

The Chief General Manager (Hydro & Civil), APGCL, Bijulee Bhawan, Paltanbazar, Guwahati-1 invites sealed tenders in prescribed forms from bonafide, experienced and financially sound contractors/firms for the following works:

Sl. No.	Name of work	Tendered amount (Rs.) (including all taxes)	Earnest Money		Time of completion
			General (Rs.)	SC/ST/OBC (Rs.)	
1	Construction of Steel Bracing Saddle Blocks at Myntriang Small Hydro Electric Project, Stage-I, APGCL, Karbi Anglong (Group A)	1543591.26	30872.00	15436.00	40 Days
2	Construction of Steel Bracing Saddle Blocks at Myntriang Small Hydro Electric Project, Stage-I, APGCL, Karbi Anglong (Group B)	1397274.58	27945.00	13973.00	40 Days

The bid documents may be obtained from the office of the Chief General Manager (Hydro & Civil), APGCL on written request to the Chief General Manager (Hydro & Civil), during office hours on all working days w.e.f. 07/02/2020 to 11/02/2020 on payment of Rs. 1000.00 (Rupees one thousand only) (non-refundable) for each work in the shape of Demand Draft only from Nationalized/Schedule Bank in favor of Deputy General Manager (F&A), APGCL. The bid documents may also be downloaded from APGCL's website www.apgcl.org.

The cost of bids is to be deposited separately with the downloaded tenders alongwith Earnest Money. The tenders will be received up to 1.00 P.M. of 11/02/2020 and will be opened at 3.00 P.M. on the same day in presence of the tenderers or their authorized representatives. The bidders are to quote their rates against each item in clear money (Rupees) value per unit of work.

The Chief General Manager (Hydro & Civil), APGCL is not bound to accept the lowest rate and reserves the right to accept or reject any or all tenders without assigning any reason thereof. Any addendum/corrigendum in respect of this tender shall be issued on APGCL's website: www.apgcl.org

Chief General Manager (Hydro & Civil),
APGCL.

Memo No. APGCL/CGM (H&C)/W/2019-20/813/4(a)

Date: 06/02/2020

Copy to: -

- 1) The Managing Director, APGCL, Bijulee Bhawan, Paltanbazar, Guwahati-1, for favour of kind information.
- 2) The Chief General Manager (Gen), APGCL, Bijulee Bhawan, Paltanbazar, Guwahati-1, for information.
- 3) The Chief General Manager (F&A), APGCL, Bijulee Bhawan, Paltanbazar, Guwahati-1, for information.
- 4) The General Manager, Design (Civil), APGCL, Narengi, Guwahati-781 026, for information and wide circulation.
- 5) The General Manager, KLHEP, APGCL, Lengery, West Karbi Anglong for information and wide circulation.
- 6) The Deputy General Manager, Investigation Circle, APGCL, Narengi, Guwahati-781 026, for information and wide circulation.
- 7) The Project Manager, MSHEP, APGCL, Lengery, West Karbi Anglong, for information and necessary action.
- 8) The P.R.O., APDCL, Bijulee Bhawan, Paltanbazar, Guwahati-1 for information with a request to publish the NIT in 1 (one) issue of Local Dailies in Regional and English language on or before 07/02/2020.
- 9) Office Notice Board
- 10) Relevant file

Chief General Manager (Hydro & Civil),
APGCL.

CHAPTER-II

1 TERMINOLOGY

- 1.01** APGCL wherever used in this document shall mean Assam Power Generation Corporation Limited incorporated vide The Companies Act 1961 in exercise of Powers conferred under the Act including subsequent amendments, if any. APGCL is a successor company of ASEB.
- 1.02** CGM (H&C) or owner or purchaser or project authority wherever used in this document shall mean the officer holding the post of the Chief General Manager (Hydro & Civil) APGCL, Guwahati (Assam), who or his authorized representative will exercise authority on behalf of the Department in respect of the Tender and the works specified herein.
- 1.03** Engineer-in-Charge/or engineer shall mean the Officer holding the charge of the Departmental post of General Manager/ Assistant General Manager (Civil) pertaining to supervision of works specified in this document.
- 1.04** The term 'Contractor' wherever used in this document shall mean the individual/firm or company who shall have entered into a contract agreement with the owner or the project authority, undertaking on his behalf to carry out the works in full or in part as may be specified in contract documents, and shall include in the case of an individual/ his heirs, administrators and permitted assignees, in case of a firm, the partners of the said firm, their respective heirs, executors, administrators and permitted assignees, and in case of a Company its successors and permitted assignees.
- 1.05** Contract documents shall mean and comprise the following documents and shall be the basis of agreement between the owner and the contractor for carrying out the works in accordance with the terms and conditions, specifications, drawings and directions contained in the said documents.
- a) Bid documents duly filled in respect of rates, process & signed, the tender forms properly filled in, signed and dated by the contractor & duly submitted.
 - b) Contractor's original bid proposal and subsequent correspondences relating to clarifications and negotiations, if any, prior to award of the contract.
 - c) Equipment, specifications and drawings, so far as applicable
 - d) Approved agreement forms duly signed, dated and sealed by the contractor and the owner as specified in the said forms
- 1.06** 'Equipment' and 'Plants' shall mean and include all sorts of machineries and accessories, apparatus, instruments, components manufactured articles and parts etc. to be supplied or provided by the contractor under the terms of the contract , unless otherwise specified
- 1.07** The 'Works' shall unless be repugnant to such description shall be construed and taken to mean the works contracted, or by virtue of the contract agreement, to be executed whether temporary or permanent and whether original, altered, substituted or additional.
- 1.08** The expression 'Specifications' wherever used in this document shall mean all the pertinent terms and stipulations furnished herein in respect of the work or part thereof and/or indicated in the drawings appended hereto and to be issued for construction and shall have reference also to other relevant terms and stipulations not furnished herein, but as far as applicable.

CHAPTER-III

INSTRUCTION FOR BIDDERS AND SPECIAL CONDITIONS

NIT No.: Tender Notice No. 21 of 2019-20 of CGM (H & C) Dated: -06/02/2020

BID INVITATION FOR: Construction of Steel Bracing Saddle Blocks at Myntriang Small Hydro Electric Project, Stage-I, APGCL, Karbi Anglong (Group A)

EARNEST MONEY DEPOSIT: Rs. 27,945.00 (for General)
Rs. 13,973.00 (for SC/ST/OBC) (For Individual only)

1. DUE DATE AND CLOSING TIME

The bid will be received up to 1.00 p.m. on 11.02.2020. The opening time of the bids will be at 3.00 p.m. on the same day and the venue will be the office of the Chief General Manager (Hydro & Civil), APGCL. Bidders or their authorized representatives will make it convenient to attend the bid opening on time.

2. TIME OF COMPLETION OF WORK

The stipulated time of completion of the work is 40 (forty) days from the date of handing over the site.

3. BID-GUARANTEE OR EARNEST MONEY DEPOSIT: (E.M.)

3.1 Every bid or tender shall be accompanied by a deposit of E.M for an amount indicated in the Tender Notice pertaining to the work (ordinarily equivalent to 2% of the estimated value of work, unless otherwise specified in the Notice), in the form of an acceptable **Demand Draft only from a Nationalized/Schedule Bank pledged in favour of the Deputy General Manager (F & A), APGCL, Guwahati**. Irregular tender is liable to be rejected.

3.2 The E.M. as mentioned above will be returned to the respective unsuccessful bidder soon after the award of the contract. The E.M. will be retained towards the contract security deposit in the case of selected bidder or bidders in whose favour the contract is awarded. The APGCL will not entertain any claim for release of the E.M. during pendency in selection of contractors for awarding the contract. The APGCL will not pay any interest on the E.M. deposit.

3.3 The E.M. is liable to be forfeited in the absolute discretion of the CGM (H&C), APGCL, if a selected bidder revokes or causes to withdraw his offer / tender before the expiry of its validity or fails after the contract is awarded to him to execute the 'Contract agreement' with the APGCL described herein after (so far as applicable) or to commence the work within the period as notified in the work order.

4. PERFORMANCE –GUARANTEE OR SECURITY DEPOSIT (S.D.)

4.1 The security to be taken for due performance of the contract in terms of the 'contract agreement' will be a deduction of 10% (ten percent) from every ad-interim payment made on account of works performed, until the sum of these deductions and E.M. together becomes equal to 10 (ten) percent of the total executed value.

4.2 Such S.D. shall be forfeited or appropriated by the CGM (H&C), APGCL, BijuleeBhawan, Guwahati under authority of the owner in his discretion towards any loss, damage etc. that may be sustained by the APGCL as a result of breach of any terms, conditions of the contract by the contractor, notwithstanding other remedies open to the APGCL under the terms of the contract or law.

4.3 In the event of contractor's Security Deposit being appropriated towards loss, damage etc, the contractor shall forthwith recoup the amount to restore the Security Deposit to the full current value within 30 (thirty) days from the date of intimation.

4.4 Subject to the provisions mentioned above and the provisions of guarantee period of **one year**, the Security Deposit will be returned to the contractor on the due and satisfactory **completion** of the contract and after all claims of the APGCL shall have been settled. The APGCL will not pay any interest on the amount of Security Deposit of Performance Guarantee.

5. GST / INCOME TAX CERTIFICATE (PAN / GST):

- 5.1 The offered rates and / or prices for the work shall include all taxes, duties, forest royalties, monopolies etc. as may be applicable on material and labour during the tenure of the contract. There will be no reimbursement for any increase or levy of new taxes, duties etc. on materials utilized for this work or equipment furnished / supplied for completing the work or for machineries, equipment, tools and tackle, fuel and lubricants etc. used in connection with the performance of the work, unless otherwise specified or qualified by the bidder in his bid. If, however, any tax or duty is levied by the Govt. or statutory body on the finished work (after complete installation and / or delivery), such tax or duty will be to the account of the APGCL.
- 5.2 **The contractors must have a valid GST Registration No. and should submit copy of GST Certificate and attested copy of PAN Card.**
- 5.3 **Caste certificate must be produced where necessary.**

6. BIDDER'S QUALIFICATIONS:

- 6.1 The Bidder should submit a list and description of similar or comparable works previously executed by him successfully during last 3 (three) consecutive financial years indicating the individual volume and contract price along with the name and address of the respective owner / authority.
- 6.2 All prospective bidders are hereby notified that, before any bid submitted in response to this invitation is considered for award, the CGM (H&C), APGCL may require the bidder to submit a further statement of facts in detail as to the previous experience of the bidder and financial resource available with him for performing the contemplated work. The CGM (H&C), APGCL expressly reserves the right to reject any bid or which the facts as to business, financial and other resources or business experience, compared with the work bid upon, justify such rejection.
- 6.3 The Bidder should submit valid Labour License Certificate.
- 6.4 Civil Engineering firms/contractors with adequate experience must complete similar works having total value not less than **Rs. 7.72 lakh (50% of the tendered amount) during the last 5 (five) financial years** i.e. from April starting to March ending. They must submit such completion certificate with the tender.
- 6.5 Cost overrun shall not be accepted.
- 6.6 Contractors should be financially sound to invest the amount and should submit necessary evidence on this account. **Annual turnover should not be less Rs. 7.72 lakh in the last three Financial Years i.e. 2018-19, 2017-18, 2016-17.**
- 6.7 It should be ensured that the contractors shall have **Provident Fund Code No.** It will be ascertained that all the workers engaged by the contractor directly should be registered for Employees' Provident (EPF) and due contribution have been credited into their account.

7. BIDDER SHOULD EXAMINE & UNDERSTAND

- 7.1 All prospective bidders are required to thoroughly study and carefully examine all the terms and conditions, instructions, drawing & specifications pertaining to the work and visit the field of work to fully satisfy and acquaint themselves about the nature and location of work, the configuration of the ground. The spring level, the surface conditions, quality and quantity of materials required and their availability the type of equipment and facilities needed preliminary to and during the execution of the work and local conditions which may affect the work or cost thereof. Failure to do so will be at the bidder's risk.

8. SUBMISSION OF TENDER

- 8.1 Bidders are to quote their rates against each item in clear money (Rupees) value (both in figures and words) per unit of work in the prescribed format. It may be noted that in the tender portal, rates are to be quoted for all the items of the estimate of the BOQ; otherwise the price bid of that bidder will be rejected.
- 8.2 **The rates quoted by the bidders will be inclusive of all taxes, royalties and other statutory levies as applicable.**
- 8.3 The specification of the items in BOQ shall be as per the APWD SOR. If any items of the BOQ are not in the SOR then its specifications shall be as per relevant drawings/ additional specifications.

- 8.4 Bidders should note that unusually low rates not feasible for execution may not be technically accepted.
- 8.5 Bidders should note that during the time of execution of work, any item not covered by the schedule of work if required to be done as per decision of the CGM (H&C)/ Engineer-in Charge of APGCL, they have to execute such work/works as supplementary item of works, rates of which will be calculated by using the following formulae:

$$R = (T'/T) * P$$

where, R= Rate of supplementary item of work

T'= Bid value

T= Tendered value

P= Accepted Rate for the work on S.O.R. APWD Building (Civil Works) for the year 2013-2014.

If the rate of such supplementary item/items is/are not available in the aforesaid S.O.R, the same will be analyzed by the department as per reasonable market price but in any case of dispute for rate of supplementary item/items, the decision of CGM (H&C) will be final and conclusive.

- 8.6 **The quoted rates will be firm for entire period of completion of the work and no price escalation will be admissible.**
- 8.7 Firms submitting tender should enclose a certified copy of the Firm's constitution and a certified copy of Power of Attorney authorizing a person to operate the tender and contract and should furnish full address of the partners and the persons holding power of attorney on behalf of the firm.
- 8.8 **Information regarding litigation, current or during the last five years, in which the Bidder is involved with APGCL/AEGCL/APDCL, must be furnished, if any in the form of declaration. If there is no litigation, then the bidder is requested to submit NIL in the form of declaration.**
- 8.9 In the event of the date specified for bid receipt and opening being declared as a closed holiday for Purchaser's office, the due date for submission of bids and opening of bids will be the following working day at the appointed date and place.
- 8.10 The Corporation cannot be held responsible for non-receipt and postal delay.
- 8.11 Every page of the tender document to be duly signed by the bidder.

9. AWARD OF CONTRACT

- 9.1 The contract will be awarded to that responsible bidder whose bid, confirming to the schedule conditions of contract and specifications will be most advantageous to the Department, price and other factors considered. An award mailed (or otherwise furnished) to the successful bidder within the time for acceptance specified in the bid will result in a binding contract without further action by either party. The CGM (H&C), APGCL does not bind itself to accept the lowest bid or any bid. As the interest of the Department may require, the right is reserved to reject any or all bids and to waive any minor informality or irregularity in bids received without assigning any reason thereof. Bid which are incomplete or which contain undesirable conditions are liable to rejection.
- 9.2 **APGCL will try to make timely payment of bills, but on unavoidable circumstances cannot guarantee timely payment of bills, for which no interest on the payable amount will be entertained.**

10. CONTRACT AGREEMENT

- 10.1 The 'Contract agreement' (or Tender Agreement) for the works will be drawn up with the selected bidder/bidders within 7 (Seven) days of issue of the work order and the contract documents will comprise as described herein before.
- 10.2 The conditions of the F-2 form shall form part and parcel of the agreement. However wherever there is any contradiction or variation between the conditions of the F-2 form, the terms and conditions specified elsewhere in this document, the later will be treated as superseding the former. Terms and conditions shall be as per F-2 Form of agreement and has to follow accordingly. In the Form-F-2 all the designations appearing as Executive Engineer/Sub

divisional Officer shall be read as Chief General Manager (Hydro & Civil), Assam Power Generation Corporation Limited (herein after called as C.G.M (H&C), APGCL).

- 10.3 In a case where the selected bidder fails to commence the work as shall be notified in the work order or fails to execute the tender agreement with the CGM (H&C), APGCL as stipulated herein before; the CGM (H&C), APGCL reserves the right to claim loss, damage etc. and take appropriate action under the terms of this document or law including forfeiture of E.M.

11. **TOOLS & PLANTS**

- 11.1 The APGCL shall not furnish any tools & tackle, plants and equipment or such facilities for carrying out the work by the contractor (excluding hypothecation). The contractor shall arrange and maintain the equipment required for implementation of work all throughout the period of the contract.

12. **MATERIALS & LABOUR**

- 12.1 All materials (this includes without limitation raw materials, parts, components etc.) and labour required for carrying out the work shall be arranged and furnished by the contractor all throughout the tenure of the contract and strictly conform to relevant IS Code (latest revision).
- 12.2 The intending tenderers should inspect the prospective sources of collection of raw materials and fully satisfy him about the quality of materials, availability of materials, lead, and mode of transportation. The Department shall not consider, after acceptance of the contract, to pay any extra charge for lead or any other reasons, in case the contractor found later on, to have misjudged, the quality/quantity of availability of such materials from the source of collection.
- 12.3 APGCL shall not issue any construction materials such as cement, reinforcement bar, or any other materials.
- 12.4 In connection with the performance of work throughout the tenure of the contract, the engagement of labour and payment therefore by the contractor shall conform to the statute, the pertinent law or act of the Central & State Govts, as well as rules, regulations and orders of the local authorities or statutory bodies, as may be in force from time to time.
- 12.5 The materials procured for the work by the contractor shall be placed at site properly for inspection of Engineer-in charge before utilization. Any defecting materials should be replaced immediately for which no extra charge will be payable to the contractor.

13. **CHANGES IN QUANTITY AND ITEM**

- 13.1 The CGM (H&C), APGCL may at any time, by a written order make changes within the general scope of the contract, in any one or more of the following
- i) Quantity of any item
 - ii) Alteration or omission of any item
 - iii) Addition of any item
 - iv) Alteration in drawings, designs or specifications

If any such change causes an increase or decrease in the cost of or the time required for performance of the contract, an equitable adjustment shall be made in the contract price or time schedule or both and the contract shall be modified in writing accordingly. Any claim by the contractor for adjustment under this clause must be asserted within 30 days from the date of receipt by the contractor of the notification of change: PROVIDED HOWEVER, that the CGM (H&C) if decides that the facts justify such action, may receive and act upon any such claim asserted at any time prior to final payment under the contract. Failure to agree to any adjustment shall be a dispute concerning a question of fact within the meaning of the disputes mentioned herein after. However nothing in this clause shall excuse the contractor from proceeding with the contract as changed.

14. **INSPECTION**

- 14.1 All works and all supplies (this term includes without limitation raw materials, parts, components, intermediate assemblies and end products) under the contract shall be subject to inspection and test by the CGM (Hydro & Civil), APGCL or his authorized person to the extent practicable at all times and places including the period of construction or manufacture and in any event prior to final acceptance.

- 14.2 In case any work or part thereof or/and any supply is found defective in material or workmanship or otherwise not in conformity with the specifications or drawings or requirements of the contract, the CGM (Hydro & Civil), APGCL shall have the right either to reject them or to require their correction, as directed by the department.
- 14.3 The inspection and test by the CGM (Hydro & Civil), APGCL or his authorized person of any work or any supplies does not relieve the contractor from any responsibility regarding defects or other failures to meet the contract requirements which may be discovered prior to final acceptance. Except as otherwise provided in this contract final acceptance shall be conclusive except as regards latent defects, fraud or such gross mistakes as amount to fraud.
- 14.4 The contractor shall provide and maintain an inspection system acceptable to the CGM (Hydro & Civil), APGCL covering the works and/or supplies hereunder. Records of all inspection works by the contractor shall be kept complete and available to the CGM (Hydro & Civil), APGCL during the performance of this contract.
- 15. FORCE MAJEURE**
- 15.1 Force Majeure shall cover only act of God, Fire, War, Strikes, Riots and Civil Commotion, Act of Government etc. Any constraints other than those specified above will not constitute force majeure condition. In view of the other constraint beyond the control of the Contractor primarily due to statutory compulsion, extension of execution may also be considered on individual merit of the case. In case of Force Majeure condition the contractor shall notify such condition to CGM (H&C) within 15 (fifteen) days from the beginning of such delay in writing for consideration and acceptance.
- 16. LIQUIDITY DAMAGE**
- 16.1 The liquidated damages shall be payable for delay in completion of the work @ 1 % (one percent) of the executed value per week. The liquidated damages so payable shall not exceed 10% (ten percent) of the executed value. However, the payment of liquidated damages shall not in any way relieve the Contractor from any of its obligations to complete the works or from any other obligations and liabilities of the Contractor under the Contract.
- 17. TERMS OF PAYMENT**
- 17.1
- 1) **1st and Final Account Bill shall be entertained only after completion of 100% of total work.**
 - 2) Bills shall be entertained on the basis of actual measurement of completed works as per standard procedure.
 - 3) Every payment shall be made subject to the availability of fund.
- 18. CONTRACTUAL FAILURE:**
- 18.1 In the event of Contractual Failure of any respect on the part of the successful bidder, APGCL shall be entitled to forfeit the EMD or any money received from the bidder and may take appropriate action under the terms of the Contract or Law.
- 19. SETTLEMENT OF DISPUTE:**
- 19.1 In the event of any dispute or differences at any time arising between the parties relating to work or any other clauses or any content of the right and liabilities of the parties or other matters specified therein or with reference to anything arising out of the such dispute or differences shall be endeavored to be resolved by mutual negotiation. If, however, such negotiation is infructuous, the dispute should be finally settled through Arbitration and Conciliation Act 1996 by three arbitrators appointed in accordance with the said Act. The decision of the arbitrator shall be final & binding upon the parties and the expense of the arbitration shall be paid as may be determined by the arbitrator in accordance with provisions of Arbitration and Conciliation Act 1996. The arbitration proceedings shall be held in Guwahati.

20. TERMINATION:

20.1 APGCL may, by not less than 7 (seven) days written notice may terminate the contract, if the contractor:

- i. Fails to remedy a failure in the performance of his obligations,
- ii. Becomes insolvent or bankrupt,
- iii. Submit to APGCL statement which has a material effect on the rights, obligations or interest of APGCL and which the contractor known to be false,
- iv. As result of force majeure, if the whole work cannot be performed for a continuous period of 90 (ninety) days. APGCL shall make payment upon termination to contractor the services performed by the contractor to the entire satisfaction of APGCL prior to date of termination.

CHAPTER-IV

SAFETY ENGINEERING & SAFETY CODE

1. SAFETY ENGINEERING

Accident prevention shall be an essential part of the programme of the contractor for all operations involve in performance of the contract under this invitation in order to reduce the cost of construction measures in terms of:

- a. Human life sacrificed
- b. Temporary and permanent injuries to workers.
- c. Loss of materials resulting from accidents.
- d. Loss of damage to equipment.
- e. The cost of workman's compensation insurance.
- f. Loss of times due to accidents.

Suitable safety programme to be developed to cope with the particular hazards for each operations of the performance of the contract.

2. INSPECTION

To ensure effective enforcement of the rules and regulations relating to safety precautions, the arrangements made by the contractor shall be open to inspect by the Engineer-in-Charge or his representative.

3. COMPENSATION

No extra charges or additional compensation will be admissible to the contractor by the department for any work done to comply with the provisions of safety Engineering and Safety Code.

CHAPTER-V

CONTRACTOR'S CAMP

1. CAMP SITES

The contractor shall provide, maintain and operate under competent direction such camp facilities convenient to the site works under this contract as are necessary for housing, feeding and accommodation of his employees. The location, construction, operation and maintenance of such camps shall be subject to the approval of the Assistant General Manager/ Engineer in charge of the site.

2. USE OF LAND FOR CONSTRUCTION PURPOSES

Such land as may be available at work- site will be allowed to be used by the contractor for construction of his camps free of charge. However, development of clearances of the land will have to be done by the contractor at his own cost. The contractor will be responsible to clear and clean the site after completion of his works and handover the land to the Engineer-in-Charge. The contractor will be liable to pay compensation for any damages done to the land or neighboring area.

3. SANITATION IN CAMP SITE:

The temporary sanitation in the campsite should be properly maintained and hygienic so that pollution can be controlled and just before completion of the work site must be cleared properly.

CHAPTER-VI

DECLARATION

I / We hereby declare that I/we shall treat the tender documents and other records connected with the works as secret/confidential and shall not communicate information derived there from to any person other than person to whom I//We/am/are authorized to communicate the same or use the information to any manner prejudicial to the safety of the state.

Signature of the tenderer

Full Name

(In Block letters)

Address

.....

.....

.....

Phone/ Mobile

Date:

CHAPTER-VII

DECLARATION OF LITIGATION

Information on litigation history in which bidder is involved

Employer (APDCL/APGCL/AEGCL)	Cause of Dispute	Amount involved	Remarks showing present status

CHAPTER-VIII

Schedule of work:

ANNEXURE-A

To,

The Chief General Manager (Hydro & Civil),
APGCL, Bijulee Bhawan,
Paltanbazar, Guwahati-1

Sub: Submission of tender for the work “Construction of Steel Bracing Saddle Blocks at Myntriang Small Hydro Electric Project, Stage-I, APGCL, Karbi Anglong (Group B)”

Ref: Your Tender Notice No. 21 of 2019-20 of CGM (H&C) Dated: 06/02/2020

Dear Sir,

In response to your above notice I/We am /are submitting herewith, my / our rates for the work as mentioned below. Necessary documents, as asked for, are enclosed herewith, for your kind perusal.

A. Schedule of items for the work “Construction of Steel Bracing Saddle Blocks at Myntriang Small Hydro Electric Project, Stage-I, APGCL, Karbi Anglong Group (B)”

Sl. No.	Description of Item	Unit	Quantity	Rate	Amount (Rs)
1	Earthwork in excavation upto a depth of 2.0 m below existing ground level in hard/dense soil for footings of column, tie beams etc. including refilling (return filling) the quantity as necessary after completion of work, breaking clods in return filling, dressing, watering and ramming etc. and removal of surplus earth with all lead and lifts as directed and specified in the following classification of soils including bailing out water where necessary as directed and specified.	cum	58.27		
2	Providing stone soling of thickness 150 mm in foundation and under floor with best quality picked jhama brick, sand packed and laid to level and in panel after preparing the subgrade as directed including all labour and materials and if necessary dewatering, complete.	sqm	57.34		
3	Plain cement concrete works of proportion with 1 cement: 3 sand :6 coarse aggregate by volume coarse aggregate of sizes 13 mm to 32 mm in foundation bed for footing steps, walls, brick works etc. as directed and specified including dewatering if necessary, and curing complete (shuttering where necessary shall be measured and paid separately).	cum	1.11		

4	Providing and laying reinforced cement concrete of M20 grade or proportion 1:1.5:3 with coarse sand & 20 mm downgraded stone aggregate including dewatering if necessary, and curing complete but excluding cost of form work and reinforcement for reinforced cement concrete work. (form work and reinforcement will be measured and paid separately) Foundation, footing, columns with base tie and plinth beam, pile cap, base slab, retaining walls, walls of septic tank, inspection pit and the like and other works not less than 100mm thick up to plinth level.	cum	43.31		
5	Providing form work of ordinary timber planking so as to give a rough finish including centering, shuttering, strutting and propping etc., height of propping and centering below supporting floor to ceiling not exceeding 4.0 m and removal of the same for in-situ reinforced concrete and plain concrete work in: Foundation, footings, bases of columns, pile cap, raft and mass concrete works etc. using 25 mm thick plank.	sqm	162.23		
6	Supplying, fitting and fixing in position reinforcement bars conforming to relevant I.S. Code for R.C.C. work/ R.B. walling including straightening, cleaning, cutting and bending to proper shapes and length as per details, supplying and binding with 20G annealed black wire and placing in position with proper blocks, supports, chairs, spacers etc. complete. Other ISI approved TMT reinforcement bar (SRMB/SAI/BISCON/X TECH) (For Assam Type Bldg., drain works retaining wall & boundary wall etc.)	qtl	9.75		
7	Supplying fitting and fixing M.S. angles, M.S. flat, M.S. bolts and nuts including painting with red lead paint one coat complete as directed. M. S. bolts & nuts.....	qtl	4.07		
8	Structural steel work in single sections including cutting, hoisting, fixing in position and applying a priming coat of red lead paint (up to 4.6m height) from plinth level including drilling holes, supplying, fitting and fixing with bolts and nuts or welding, if necessary as directed.				
8.01	In flat up to 25mm thickness.	qtl	46.61		
8.02	In M.S. angles, channels, Tees etc.	qtl	62.29		
9	Painting two coats (excluding priming coat) on new steel and other metal surface with enamel paint of approved brand and manufacture (Asian paint/ Berger paint/ ICI paint/ J & N paint/ Nerolac) to give an even shade including cleaning the surface of all dirt, dust and other foreign matter. Surfaces over 100 mm in width or girth. General purpose (Asian paint/ Berger paint/ ICI paint/ J & N paint/ Nerolac).	sqm	295.98		
10	Loading and unloading of structural steel and steel bars by manual means.				
10.01	i) Loading of structural steel, steel bars by manual means including a lead upto 30 m.	t	26.58		

10.02	ii) Unloading of structural steel, steel bars by manual means including a lead upto 30 m.	t	26.58		
11	Loading and unloading of coarse aggregates by manual means.	per bag	1075		
12	Loading and unloading of sand by manual means	per bag	538		
13	Loading and unloading of cement by manual means	per bag	358		

Enclose:

1. Demand Draft No.

2. Date of issue

3. Name of Bank

Yours faithfully,

Signature of contractor

Full Name

Address:-

Mobile No:-

CHAPTER-IX

DRAWINGS

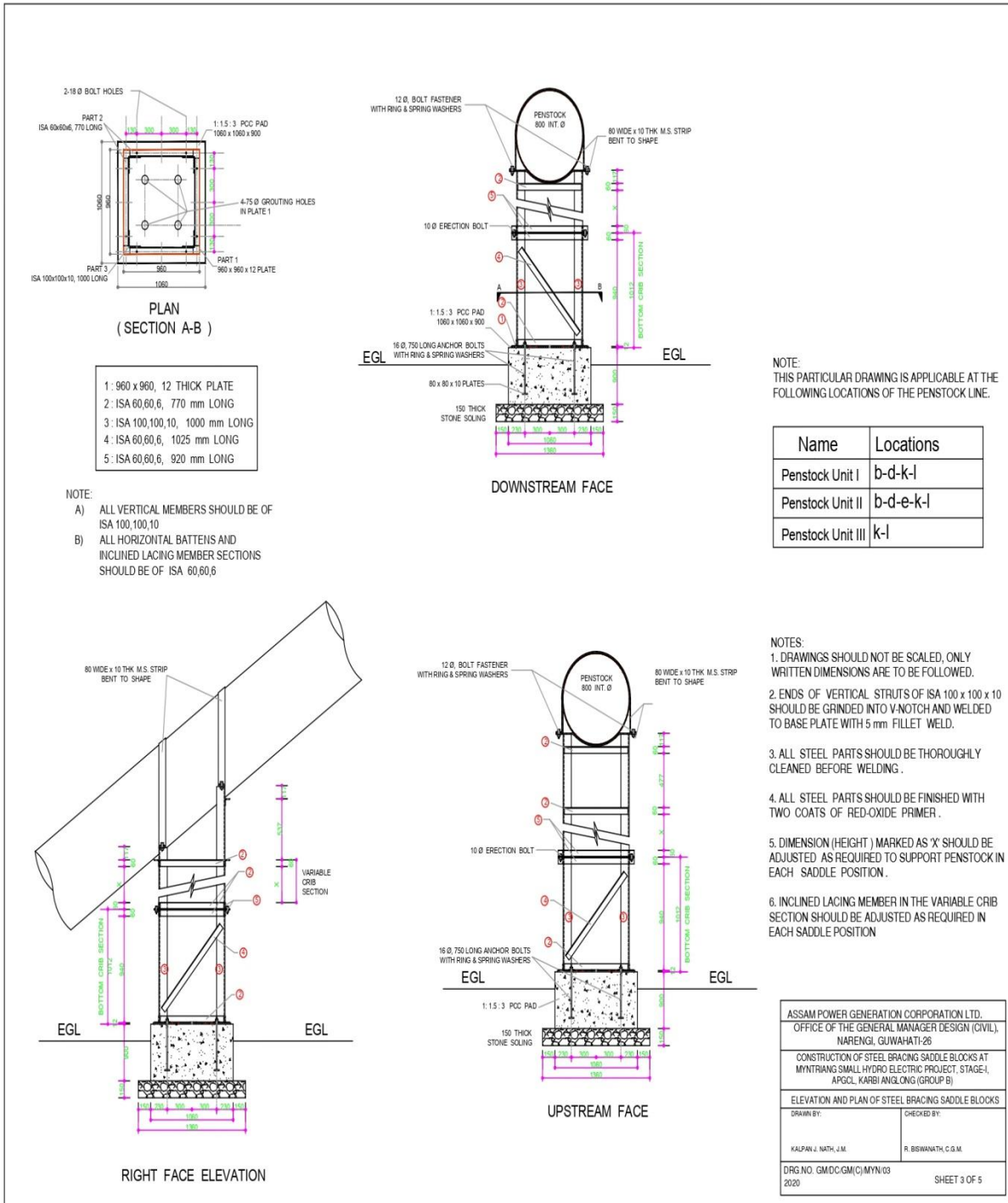

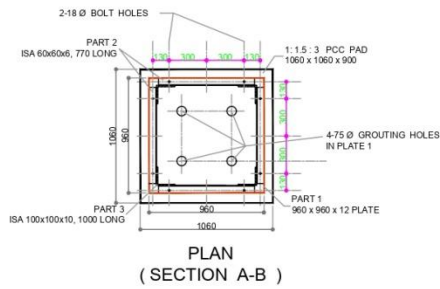

PLAN
(SECTION A-B)

- 1 : 960 x 960, 12 THICK PLATE
- 2 : ISA 60,60,6, 770 mm LONG

- NOTE:
- A) ALL VERTICAL MEMBERS SHOULD BE OF ISA 100,100,10
 - B) ALL HORIZONTAL BATTENS AND INCLINED LACING MEMBER SECTIONS SHOULD BE OF ISA 60,60,6

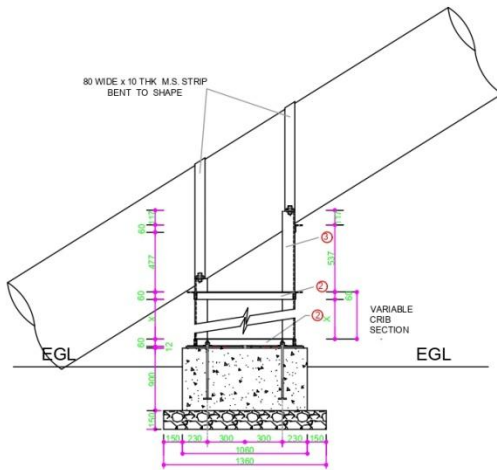

RIGHT FACE ELEVATION

NOTE:
THIS PARTICULAR DRAWING IS APPLICABLE AT THE FOLLOWING LOCATIONS OF THE PENSTOCK LINE.

Name	Locations
Penstock Unit I	m-n-o-p-q-r-s
Penstock Unit II	m-n-o-q-r-s
Penstock Unit III	b-m-n-o-q-r-s

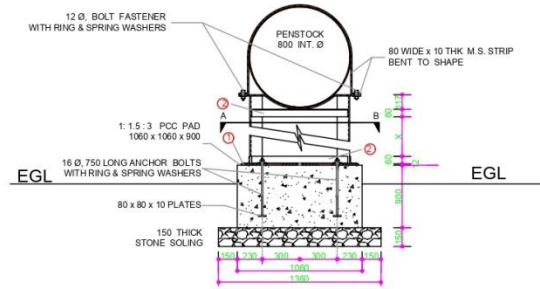

DOWNSTREAM FACE

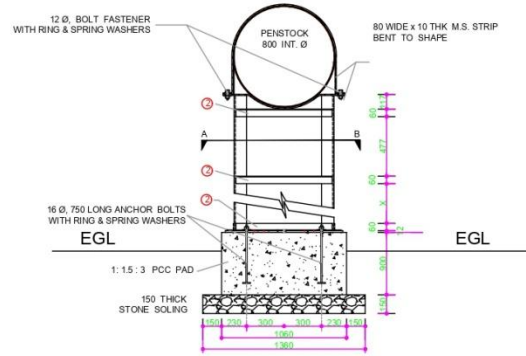

UPSTREAM FACE

- NOTES:
1. DRAWINGS SHOULD NOT BE SCALED, ONLY WRITTEN DIMENSIONS ARE TO BE FOLLOWED.
 2. ENDS OF VERTICAL STRUTS OF ISA 100 x 100 x 10 SHOULD BE GRINDED INTO V-NOTCH AND WELDED TO BASE PLATE WITH 5 mm FILLET WELD.
 3. ALL STEEL PARTS SHOULD BE THOROUGHLY CLEANED BEFORE WELDING.
 4. ALL STEEL PARTS SHOULD BE FINISHED WITH TWO COATS OF RED-OXIDE PRIMER.
 5. DIMENSION (HEIGHT) MARKED AS 'X' SHOULD BE ADJUSTED AS REQUIRED TO SUPPORT PENSTOCK IN EACH SADDLE POSITION.
 6. INCLINED LACING MEMBER IN THE VARIABLE CRIB SECTION SHOULD BE ADJUSTED AS REQUIRED IN EACH SADDLE POSITION.

ASSAM POWER GENERATION CORPORATION LTD. OFFICE OF THE GENERAL MANAGER DESIGN (CIVIL), NARENGI, GUWAHATI-26	
CONSTRUCTION OF STEEL BRACING SADDLE BLOCKS AT MYNTRIANG SMALL HYDRO ELECTRIC PROJECT, STAGE-I, APGL, KARBI ANGLONG (GROUP B)	
ELEVATION AND PLAN OF STEEL BRACING SADDLE BLOCKS	
DRAWN BY: KALPAN J. NATH, J.M.	CHECKED BY: R. BISWANATH, C.G.M.
DRG.NO. GM/DC/GM(C)/MYN/04 2020	SHEET 4 OF 5

